

REVISIONS				
REV. STYL.	E.C.O. NUMBER	DESCRIPTION	BY DATE	APPD. DATE
1		ORIGINAL RELEASE	JWD 7/29/02	RRR 7/29/02

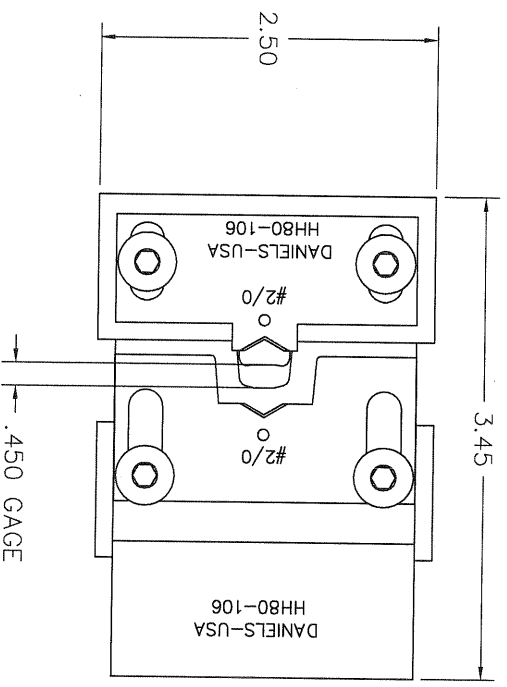
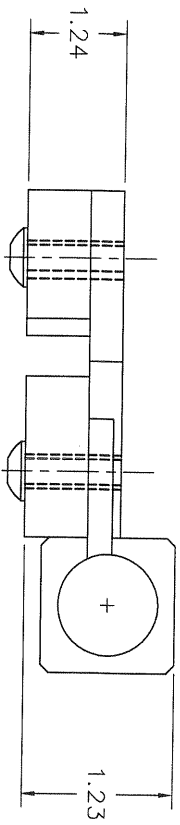

**UNCONTROLLED DOCUMENT
WILL NOT BE UPDATED
DIMENSIONS IN INCHES - UNLESS OTHERWISE SPECIFIED**

RESTRICTED & CONFIDENTIAL		CONFIDENTIAL PROPERTY OF DANIELS MANUFACTURING CORP. NOT TO BE DISCLOSED TO OTHERS, REPRODUCED OR USED FOR ANY OTHER PURPOSE EXCEPT AS AUTHORIZED IN WRITING BY DANIELS MANUFACTURING. MUST BE RETURNED TO DANIELS MANUFACTURING CORP. ON COMPLETION OF ORDER OR OTHER PURPOSE FOR WHICH LENT.	
MATERIAL		FINISH	
HEAT TREAT		FINISH	
ITEM	PART NO.	QTY.	DESCRIPTION/REMARKS
DRN. J. JOYCE	DATE 7/29/02		Daniel's Manufacturing Corp. DANIELS MANUFACTURING CORP. ORLANDO, FLORIDA CAGE 11891
CHK'D. RRR	DATE 7/29/02		
APP'D.	DATE		
NOTE: THIS DRAWING IS AN OUTLINE DRAWING OF THE RESPECTIVE INDICATED PART NUMBER AND DIM PART NUMBER IS DRAWING NUMBER WITHOUT THE "-ENV" SUFFIX.			
WHERE USED:		SCALE	SHEET OF
B		NTS	1 1
CAD P/N		DWG. NO.	REV.
HH80-106-ENV		HH80-106-ENV	1
DIE SET #2/0 ENVELOPE DRAWING			

DO NOT SCALE DRAWING