

REV. NO.	REV. DATE	REV. BY	REV. DATE	ASST. DATE
1				

**UNCONTROLLED DOCUMENT  
WILL NOT BE UPDATED**

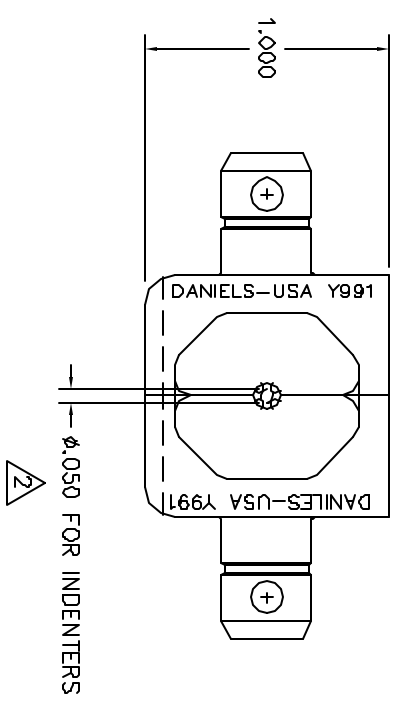
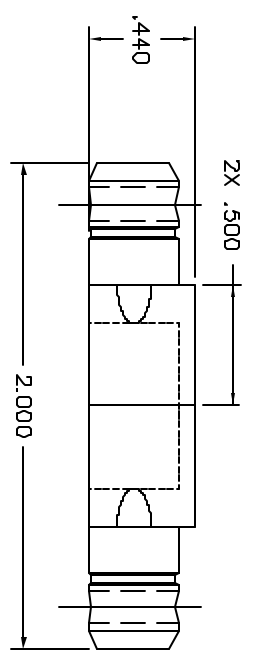

2. MEASURE INDENTER GAGING WITH DIE SET MOUNTED IN DANIELS HX4 CRIMP TOOL (OR EQUIVALENT). TOOL SHOULD BE FULLY CLOSED WITH MEASURABLE FORCE (20 LBS. MIN.) APPLIED.
1. USED TO CRIMP INLINE CRIMP SPLICE DOWATRONIC GMBH P/N PSK43637.

NOTES:

RESTRICTED & CONFIDENTIAL CONFIDENTIAL PROPERTY OF DANIELS MANUFACTURING CORP. NOT TO BE REPRODUCED OR TRANSMITTED IN ANY FORM OR BY ANY MEANS, ELECTRONIC OR MECHANICAL, INCLUDING PHOTOCOPYING, RECORDING, OR BY ANY INFORMATION STORAGE AND RETRIEVAL SYSTEM, WITHOUT THE WRITTEN PERMISSION OF DANIELS MANUFACTURING CORP. ALL RIGHTS RESERVED. MUST BE RETURNED TO DANIELS MANUFACTURING CORP. ON COMPLETION OF ORDER OR AS DIRECTED BY THE PURCHASER.		MATERIAL		ITEM		PART NO.		QTY.		DESCRIPTION/REMARKS	
		HEAT TREAT		DRN	WIP	DATE	DATE	DATE	DATE	DATE	DATE
DO NOT SCALE DRAWING		FINISH		APPRO	RRR	DATE	DATE	DATE	DATE	DATE	DATE
				TITLE		WHERE USED		SCALE		SHEET	
				DIE SET ENVELOPE DRAWING		DANIELS MANUFACTURING CORP. DANIELS, FLORIDA CASE 11857		2X		1 OF 1	
				P/N		Y991-ENV		P/N		Y991-ENV	
				REV		1		REV		1	